



NAHTM-2010

The National Association of Healthcare Transport Management

***Announces the 20th Annual Conference to be held
at Carolinas Medical Center
Charlotte, NC***

◆ Exhibits: September 14th – September 15th

***◆ Educational Sessions: September 12th –
September 16th***





**Hampton Inn
Charlotte-Uptown**

530 East Martin Luther King Jr. Blvd

\$86.00 Dbl Occupancy

***For Reservations Call
704-373-0917
and reference
NAHTM***

<http://www.hamptoninn.com/en/hp/hotels/index.jhtml?ctyhocn=CLTUTHX>

CELEBRATE NAHTM EXHIBITORS

Tuesday, September 14th – Wednesday, September 15th

Our vendors are our partners as we move on up to higher levels in the provision of comfort, safety and efficiency for staff and patients alike.

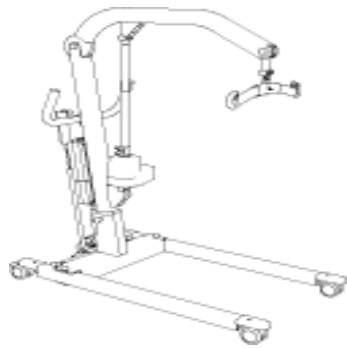



Conference 2010 Registration Fee Schedule and Registration Form

September 12th – September 16th, 2010 Conference Fees:

\$ 425.00 Early Bird (payment must be received before June 1, 2010)

\$ 325.00 Early Bird for additional registrants accompanied by two Full Members from the same institution
(1st 2 members, from the same institution, pay \$425)

\$ 475.00 for registrations received after June 1, 2010

\$ 375.00 for registrations received after June 1, 2010 for additional registrants accompanied by two Full Members from the same institution (1st 2 members, from the same institution, pay \$475)

Membership Fees: It is required that registrants for the NAHTM conference be members with active status. All members must be associated with hospital-based patient transport and/or related activities. If your membership status is not active, please send an additional \$115 for membership dues.

\$115.00 Full Member: Full benefits, including voting on all matters and the right to hold an Executive Office.

Misc. Fee:

\$ 50.00 per Additional Exhibitor and Leadership Receptions (fees for registrant is included in the conference fee)



Two Payment Methods



**Use PAYPAL to make payment on line
via ...**

www.nahtm.org

Make a Payment

OR



Remit Payment To:
Wendy Laney, Secretary/NAHTM
Carolinas Medical Center-Union
P.O. Box 5003
Monroe, NC 28111
Phone: 704-296-4073

wendy.laney@carolinashealthcare.org
Please endorse Check to NAHTM, Inc

**Do you have a favorite vendor you would like to see at the
conference?**

**Steer them to www.nahtm.org for an Exhibitor Prospectus
and registration located on the conference page**



Registration Form

Name: Title:

Hospital/ Institution:

Address: City / State / Zip:

Phone #: Fax #: E-Mail:

Referred by:

Emergency Contact Information:

Are you the Primary Registrant from your organization? Y / N Please complete and submit a separate form for each registrant from your organization.

September 12 - 15, 2010 Conference Fees

____ @\$ 425.00 Early Bird - received by June 1, 2010

____ @\$ 325.00 Early Bird - received by June 1, 2010 for additional registrant from organization (after 2 members pay full fees)

____ @\$ 475.00 after June 1, 2010

____ @\$ 375.00 after June 1, 2010 for additional registrant from organization (after 2 members pay full fees)

Annual Membership Fees

___@ \$115.00 Full Member NAHTM

---@ \$ 50.00 per Additional Banquet Guest

Misc. Fee:

Please includes additional guests name/names: _____

= _____ TOTAL FEES

Thank You!